



Applies To: **1998-02 Accord** – ALL  
**1998-04 Civic** – ALL  
**1999-03 Odyssey** – ALL  
**1997-01 Prelude** – ALL  
**2000-04 S2000** – ALL

**August 3, 2004**

## Deformed Windshield Molding

(Supersedes 00-064, dated November 18, 2003, and replaces 98-066, Deformed Upper Windshield Molding, dated March 28, 2000)

### SYMPTOM

The windshield molding is warped or deformed.

### PROBABLE CAUSE

The inner lip is folded, causing a poor fit against the body.

### CORRECTIVE ACTION

Remove the entire inner lip, and fill the channel between the molding and the body with silicone sealant.

### REQUIRED MATERIALS

3M Black Super Silicone Sealant:

3M P/N 051135-08662

(Each tube repairs about three vehicles.)

3M General Purpose Adhesive Cleaner:

3M P/N 051135-08984

(Each container repairs about six vehicles.)

### WARRANTY CLAIM INFORMATION

**In warranty:** The normal warranty applies.

Operation Number: 831004

Flat Rate Time: 0.7 hour

Failed Part: P/N 73150-S84-A01  
H/C 5443387

Defect Code: 00401

Symptom Code: 00101

Template ID: 00-064A

Skill Level: Repair Technician

**Out of warranty:** Any repair performed after warranty expiration may be eligible for goodwill consideration by the District Parts and Service Manager or your Zone Office. You must request consideration, and get a decision, before starting work.

### DIAGNOSIS

Pull up the outer edge of the windshield molding. Check if the inner lip is folded over anywhere.

- If the inner lip is folded over, go to REPAIR PROCEDURE.
- If the inner lip is not folded, disregard this bulletin, and look for other possible causes.

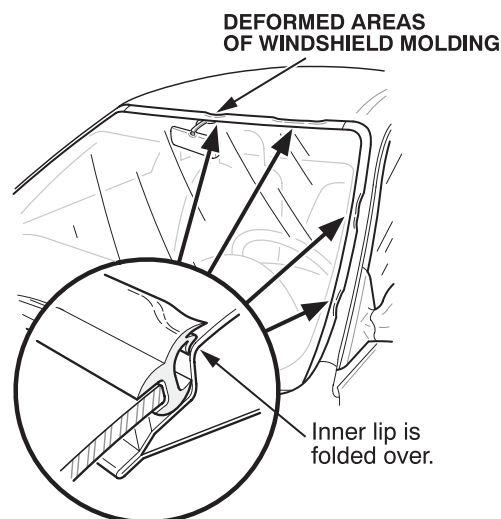

### REPAIR PROCEDURE

1. Protect the roof by applying a strip of 2-inch-wide masking tape along the outer edge of the windshield molding.

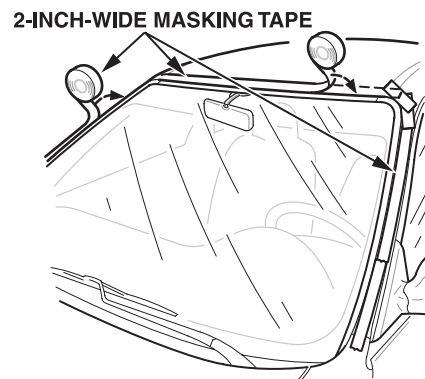

2. Pull up the outer edge of the molding, and use scissors or an X-Acto knife to remove its entire inner lip.

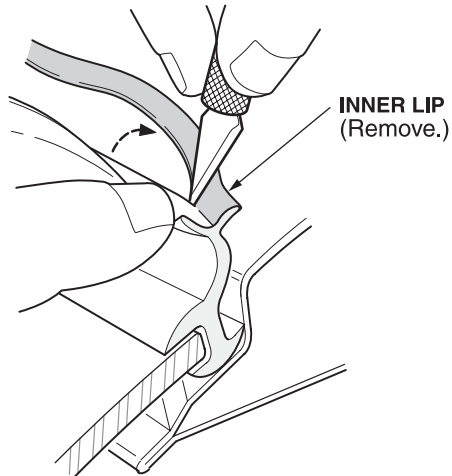

3. With an O-ring pick or similar tool, pull up the outer edge of the molding, and apply 3M Black Super Silicone Sealant under it, along the A-pillars and the upper edge of the windshield.

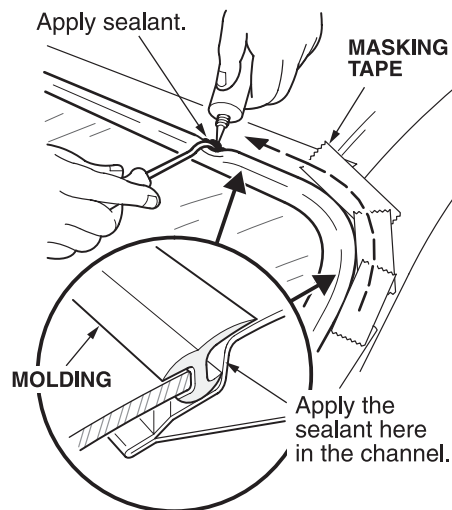

4. Push down on the molding, and smooth it out until it sits flush with the roof.
5. Wait 5 minutes, then remove the masking tape.
6. Clean up any excess sealant with 3M General Purpose Adhesive Cleaner.