

DRIVE FLANGE - AS PER HONDA S2000 O.E. FLANGE DIMENSIONS & FIXINGS.

BELLHOUSING ENGINE BOLT FACE PATTERN, CLUTCH TUBE FITMENT & CLUTCH ARM PIVOT FITMENT - AS PER HONDA S2000 O.E. DIMENSIONS & FIXINGS.

803.5 TO FLANGE FACE

742.0 TO GEAR LEVER ϕ

ALL OTHER DIMENSIONS AS PER STANDARD QBE69G GEARBOX.

365.4

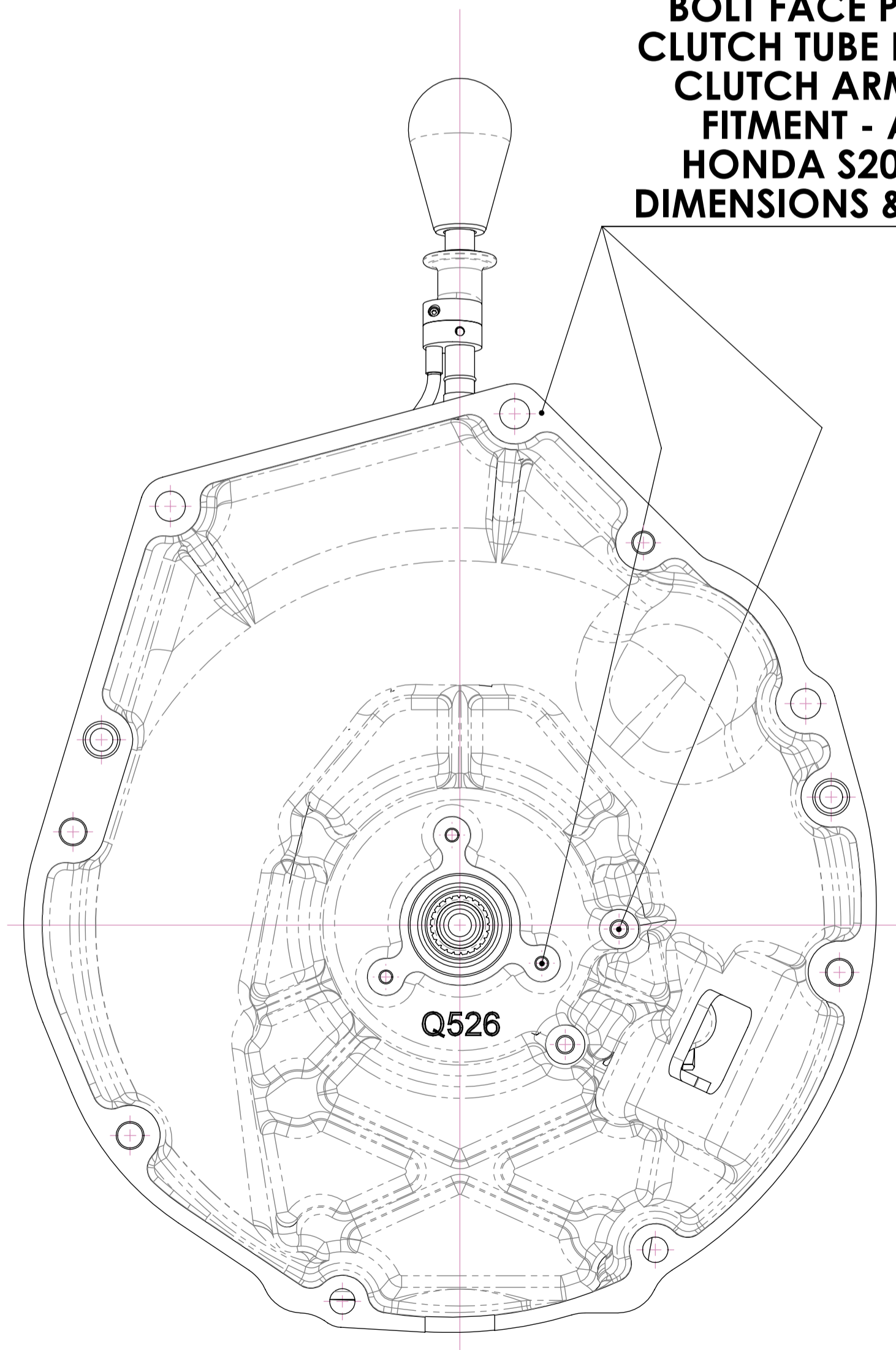

INPUT SHAFT, 24T CLUTCH SPLINE - AS PER O.E HONDA S2000.

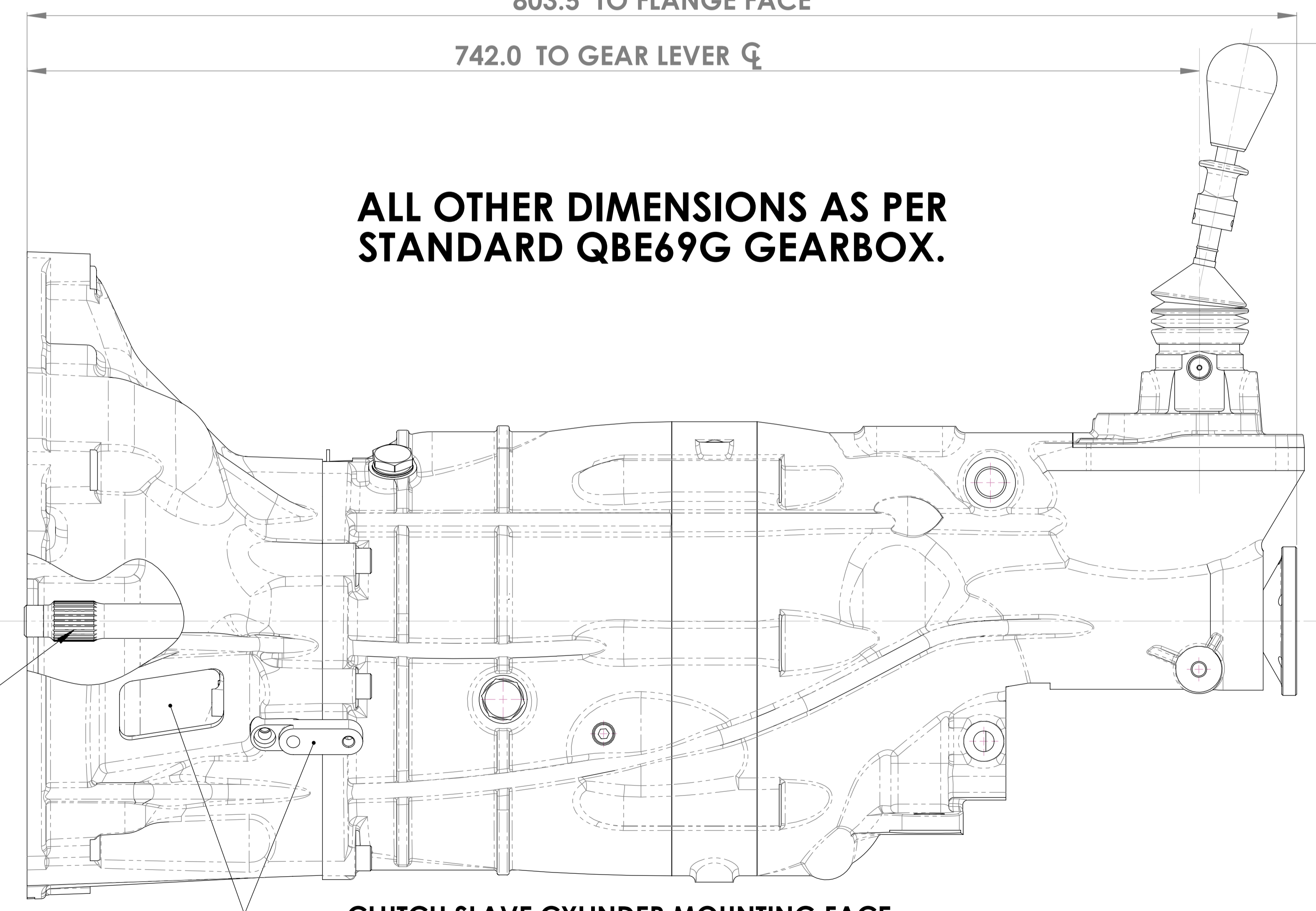

CLUTCH SLAVE CYLINDER MOUNTING FACE AND CLUTCH ARM APERTURE - AS PER HONDA S2000 O.E. DIMENSIONS & FIXINGS.

QUAIFE
DESIGN AND DEVELOPMENT

THIS DRAWING OR DESIGN IS STRICTLY CONFIDENTIAL AND THE COPYRIGHT THEREIN THE EXCLUSIVE PROPERTY OF R.F. QUAIFE ENGINEERING LTD. AND MAY NOT BE USED, COPIED OR EXHIBITED WITHOUT THEIR WRITTEN PERMISSION

UNLESS OTHERWISE STATED: ALL DIMENSIONS IN MILLIMETERS	TOLERANCES DIMENSIONS: 0 PLACES: ± 0.25 1 PLACE: ± 0.2 2 PLACES: ± 0.1
GENERAL SURFACE FINISH: 1.6	ANGLES: $\pm 0.25^\circ$
SHEET 1 OF 1	SCALE 1:5 U.O.S.

ISSUE: 01 DATE: 23.6.10 RELEASE DATE:
DRAWN BY: J.P. CHECKED BY:
MATERIAL:
BLANK SIZE:
HEAT TREATMENT:

FINISH:

DESCRIPTION: GENERAL ASSEMBLY HONDA S2000

PART No.: E-69G1-01-HONDA-S2000